

Flow Computer

Model 405

Features

- Large LCD display
- Operates from 12-28V dc or ac mains
- Scaled pulse output
- Accepts 4-20mA and frequency flow inputs
- Provides 8-24V dc transducer power
- High accuracy
- Self-adhesive engineering unit labels
- Simplified programming
- CE Compliant

Functions

- Rate
- Total (Resettable)
- Accumulated Total

Options

- 4-20mA isolated output
- RS232 and RS422/485 communications interface
- High/low alarm outputs

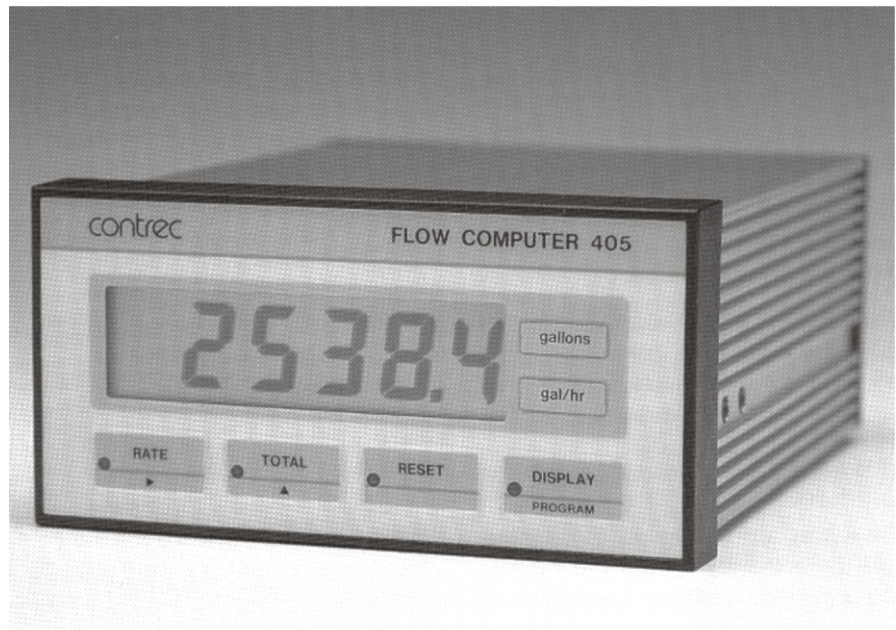

Overview

The 405 Flow Computer can handle a wide range of flow applications, where high accuracy and flexibility are required. It will interface to most flowmeters and versions are available for pulse and analog inputs.

Either the **Flow Rate** or a **Resettable Total** can be continuously displayed in engineering units on the large six digit LCD display. A non-resettable **Accumulated Total** is also displayed whenever the **DISPLAY** key is pressed.

A scaled pulse output, suitable for driving remote totalisers, is a standard feature and the instrument also provides an 8-24 Volts dc power supply for driving transducers.

RS232 and RS422/485 communications interface

Optional features include: an isolated 4-20mA output; a communications interface; and high/low flow rate alarms which are output on two Form C relays.

The communications option includes both RS232 and RS422/485 interfaces for communicating with a computer.

Software drivers are also included for a number of printers and can print a ticket with time and date, a sequential ticket number, and the resettable and accumulated totals.

Set-up data is stored in non-volatile memory

The 405 is initially set-up by following a calibration sequence that enables scaling factors, digital filtering and display formatting to be set and stored in a non-volatile memory which does not require battery backup.

The instrument will operate from 12 to 28V dc or from the 110/220V ac mains.

Each flow computer is supplied with a sheet of self-adhesive engineering unit labels. A recess, adjacent to the display, is provided in which the correct label can be placed.

Flow Computer

Model 405

Digital filtering enhances Rate accuracy

Frequency fluctuations caused by pulsating flow through a flowmeter, often makes the Rate impossible to read with any precision.

The 405 has a digital filter which will average out these fluctuations and enable the Rate to be read to a four digit accuracy.

The degree of filtering is fully programmable which means that highly accurate and stable readings can be obtained without excessive lag.

Different mounting options available

The 405 is designed for panel mounting with the facia watertight to IP65 (Nema 4X) and resistant to most chemicals.

A field enclosure and an explosion-proof enclosure are optionally available.

Models Available

Model 405A

An analog version with a fully isolated input. Inputs include 4-20mA, 0-20mA, 1-5V and 0-10V signals from flowmeters and pressure transducers. In addition to linear and square law input relationships, open channel applications can be handled via a programmable power on the input relationship.

Model 405B

A frequency input version that will accept pulse inputs and open collector inputs from opto-sensors or Hall effect devices.

Model 405D

Frequency input version with an input conditioning card capable of accepting mV signals from coils, two wire proximity sensors, reed switch inputs and most other pulse type signals.

Model 405LA

4-20mA temperature input version with temperature correction for general chemicals, LPG and petroleums to API tables (see separate data sheet on 405L and 414L).

Model 405LR

RTD temperature input version with temperature correction for general chemicals, LPG and petroleums to API tables (see separate data sheet on 405L and 414L).

Model 405Q

Frequency or pulse input with non-linearity correction and quadrature signal for measurement of bi-directional flows. The 405Q is highly suited to custody transfer applications where high accuracy and signal integrity is required.

Model 405S

For applications requiring the addition or subtraction of two flows this instrument will accept two frequency inputs and display Rate and Total for each channel.

Operation

The display of the 405 will normally show the Rate or Resettable Total (Net Total in the case of the 405LA, 405LR and 405S), as selected by the **RATE** or **TOTAL** keys on the keypad. An LED in the facia will indicate which function is currently displayed.

The **DISPLAY** key can be used to display the Accumulated Total. On the first press of the **DISPLAY** key, the display shows **ACCTOT** for one second followed by the actual total.

The Accumulated Total continuously totalises the flow and is not resettable via the front panel.

On reaching the maximum displayed total, all totals will roll over to zero and continue totalising. If, at any time, power is lost or the instrument is switched off, the totals will be stored in the non-volatile memory. When power is switched back on to the instrument, the stored totals will be recalled from memory and the totals will be incremented from the last values.

In the case of the Models 405LA and 405LR, if temperature compensation is selected, a second press of the **DISPLAY** key will show the product temperature or density if a density meter input is selected. A third press of the **DISPLAY** will show the actual Gross Total.

With the 405S, the first press of the **DISPLAY** key will show RATE 1, and the second press TOTAL 1, for input 1. The third press will show RATE 2, and the fourth press TOTAL 2, for input 2.

General

Display	6 digit 0.7" (17.8mm) high LCD.
Display Update Rate	0.25s (0.5s on 405A).
Data Retention	Set-up parameters and totals stored in non-volatile memory with 10 years retention.
Decimal Points	The number of decimal points with which the rate and totals are displayed can be programmed.
Total Conversion	It is possible to program a constant so that the rate can be displayed in one unit (eg. gal/m) and the total displayed with a different unit (eg. barrels).
Time Base	The rate can be displayed in units per second, minutes, hours or days.
Transducer Supply	8-24V dc field adjustable, 50mA maximum.
Power Requirements	
DC Supply:	11.5-28.5V dc, 130mA typical current (no options).
AC Supply:	Set internally to 85-100V, 95-135V or 190-260V.
Operating Temperature	0 to 55°C.
Rear Connection	Terminal block.
Front Panel	
Material:	Polycarbonate.
Protection:	IP65 (Nema 4X).
Case	Aluminium.

Inputs

Analog Input (Model 405A)	
Type:	Isolated 4-20mA, 0-20mA, 1-5V and 0-10V.
Input Impedance	
- Current:	250 ohms.
- Voltage:	10K ohms.
Accuracy:	0.075%.
Span:	0.1000 to 50,000.
Zero:	0.00000 to 50,000.
Cut-off Point:	A low flow rate cut-off can be programmed below which flow is not registered. The cut-off is programmed as a percentage of span.
Relationship:	Linear, square root or programmable.
Open Channel:	For open channel flowmeters the power of the input relationship is programmable between 0 and 9.99. With open channel selected, the polarity of the signal can also be programmed such that, 20mA represents maximum or minimum flow.
Frequency (Pulse) Input (Models 405B, 405D, 405Q and 405S)	
Minimum:	0Hz on Totals, 0.25Hz on Rate.
Maximum:	10kHz for single input, 2.5 for quadrature.
Input Circuits:	Will accept most sine logic and proximity switch inputs.
Scaling Range:	0.1000 to 50,000.
4-20mA Inputs	(Flow and Temperature in the Model 405LA - see separate data sheet.)
RTD Input	(Model 405LR - see separate data sheet.)

Outputs

Pulse Output (Not available for Model 405S)	
Type:	Open collector output with a pulse produced on each increment of the accumulated total.
Maximum Rate:	49 pulses per second.
Pulse Width:	10ms.
Maximum Current:	Current sinking transistor output 100mA, 30V dc maximum.
4-20mA Output	
Type:	Fully isolated output corresponding to the displayed flow rate, suitable for driving a recorder or controller. Outputs available are 4-20mA, 0-20mA, 0-10V or 2-10V, with the minimum and maximum levels programmable.
Resolution:	10 bits.
Accuracy:	<0.05%.
Maximum Load:	500 ohms from internal power, 950 ohms if externally powered.
Communications Output	
Type:	RS232, RS422 or RS485 interface is available for driving printers and communicating with computers.
Baud Rate:	300 to 9600.
Parity:	None, odd and even.
Data Bits:	7 or 8.
Protocols:	A number of protocols are included to interface to printers and computers. A real time clock provides time/date printing on tickets.
Time/Date:	
ID Code:	For multi-point communications, a unique address can be programmed.
High/Low Flow	
Type:	Two Form C relays provide a high and low flow rate alarm. Alarm points are programmable during set-up.
Maximum Current:	5A.
Maximum Voltage:	250V ac, 30V dc.
Maximum Power:	1250VA.

Approvals

Electrical	ETL (US) approved to UL508 and CSA.
Interference	CE Compliance.

Optional Enclosures

Field Enclosures	IP67 (Nema 4X).
Explosionproof Enclosures	CENELEC, FM, CSA and SAA approved enclosures available for hazardous areas.

Important: Specifications are subject to change without notice.

Dimension Drawings

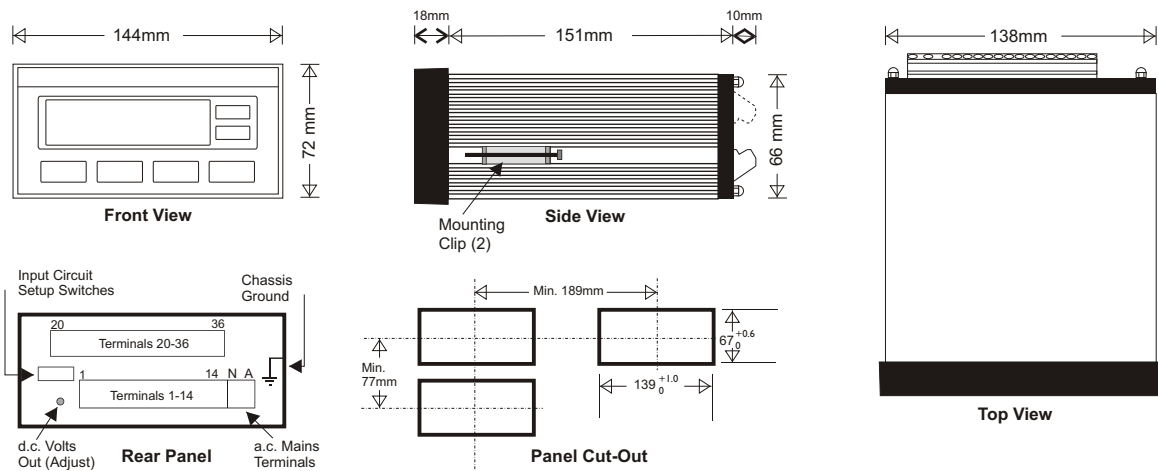

Terminal Descriptions

Terminals Common to all Models	
No.	
1	Calibration
2	Switch Common
11	DC Power Out
12	DC Ground
13	DC Power In

RS232/422 Option (All Models)	
No.	
20	RS232 Signal Ground
21	RS232 Data In
22	RS232 Data Out
23	RS422 (-) Data Out
24	RS422 (+) Data Out
25	RS422 (-) Data In
26	RS422 (+) Data In
27	RS232 CTS

Isolated 4-20 mA Output Option	
No.	
20	Not Used
21	0 Volts
22	0-10 Volts Out
23	-12 volts
24	I (-)
25	I (+)
26	+15 Volts
27	Not Used

High & Low Relay Alarm Option	
No.	
31	High - Normally Open
32	High - Normally Closed
33	High - Common
34	Low - Normally Open
35	Low - Normally Closed
36	Low - Common

Terminals 28, 29 & 30 on the option card are not used.

Terminals specific to each model

No.	405A	405B	405D	405LA	405LR	405Q 405S	No.
3	Rate Switch	Not Used	Rate Switch	Flow Input Ch. 2	Flow Input Ch. 2	Flow Input Ch. 2	3
4	Total Switch	Not Used	Total Switch	Not Used	PT100 (+)	Not Used	4
5	Reset Switch	Not Used	Reset Switch	Temp. (4-20mA)	PT100 Signal (+)	Not Used	5
6	Program Switch	Not Used	Program Switch	Not Used	PT100 Signal (-)	Not Used	6
7	Not Used	Not Used	Not Used	Flow Alarm	Flow Alarm	Flow Alarm	7
8	Flow Common	Flow Common	Flow Common	Flow Common	Flow Common	Flow Common	8
9	Flow Signal (mA)	Flow Signal	Flow Signal	Flow Input Ch. 1	Flow Input Ch. 1	Flow Input Ch. 1	9
10	Pulse Out	Not Used	Pulse Out	Pulse Out	Pulse Out	Pulse Out	10
14	Flow Signal (Volts)	Not Used	Not Used	Flow Input (4-20mA)	PT100 (-)	Not Used	14

Ordering Information

When specifying please indicate model(s) required using the following method.

405 D . 1 0 E 0

<p>Basic Model</p> <p>Type of Input</p> <p>Analog Input - A</p> <p>Pulse Input - B</p> <p>Pulse or frequency input with signal conditioner - D</p> <p>Liquid temperature compensation (4-20mA) - LA</p> <p>Liquid temperature compensation (RTD) - LR</p> <p>Quadrature pulse input - Q</p> <p>Addition/Subtraction of two flows - S</p>		<p>Special Options</p> <p>0 - No Option</p> <p>B - Backlighting</p> <p>C - Conformal Coating</p> <p>Power Supply</p> <p>E - 220-240V ac</p> <p>A - 110-120V ac</p> <p>D - 12-28V dc</p> <p>J - 100V ac</p> <p>Output Options</p> <p>0 - No options</p> <p>1 - Isolated 4-20mA output</p> <p>2 - RS232/422/485</p> <p>3 - High/Low alarms</p> <p>4 - 4-20mA and alarms</p> <p>5 - RS232/422/485 and alarms</p> <p>Mounting Options</p> <p>1 - Panel mount</p> <p>N - Field mount enclosure</p> <p>3 - Explosionproof enclosure (CENELEC)</p>
--	--	---

contrec

Distributed by:

Contrec Pty Ltd
 22 Hall Street Hawthorn East, Melbourne 3123 AUSTRALIA
 Tel: +61 3 9822 8966 Fax: +61 3 9822 8329 Email: sales@contrec.com.au
 d Delft Instruments company

Contrec - USA, LLC
 916 Belcher Drive Pelham AL 35124 USA
 Tel: (205) 685 3000 Fax: (205) 685 3001 Email: contrec@contrec-usa.com

Contrec Europe Limited
 PO Box 436 Sowerby Bridge, West Yorkshire HX6 3YA, UK
 Tel: +44 1422 829 940 Fax: +44 1422 829 941 Email: sales@contrec.co.uk

Website: www.contrec.com.au